

Advantages

- High reliability
- Excellent accuracy
- Low thermal drift
- Fast response time
- Excellent linearity

Closed Loop Type



Specifications

Ta=25°C

Product name	Code:3082		CSC-15J
	Symbol	Unit	
Nominal input current	If(n)	A	±150
Saturation current	If(s)	A	±300
Nominal Output current	Iout	mA	I _o ±150 [at If(n)]
conversion ratio			1 : 1000
Offset current	I _o	mA	0±0.15 [at 0A]
Supply Voltage	Vcc	V DC	±15±5%
Consumption Current	Icc	mA	20 + Iout
Response Speed	Trr	μ sec	1 Max. [at di/dt=100A/μ sec]
Thermal Drift of Vh		%/°C	±0.05 Max. [at If(n)]
Thermal Drift of I _o		mA/°C	±0.012 Max. [at 0A]
Dielectric Strength		kV	AC 2.5 [with 50 or 60 Hz 1min.]
Insulation Resistance		Ω	500M Min. [at 500V DC]
Operating Temperature	Ta	°C	-20 to +80
Storage Temperature	Ts	°C	-25 to +85
Hysteresis Error		mA	±0.15 Max. [at If --> 0]
Secondary coil resistance		Ω	11 [at 80°C]

Dimensions

Unit : mm

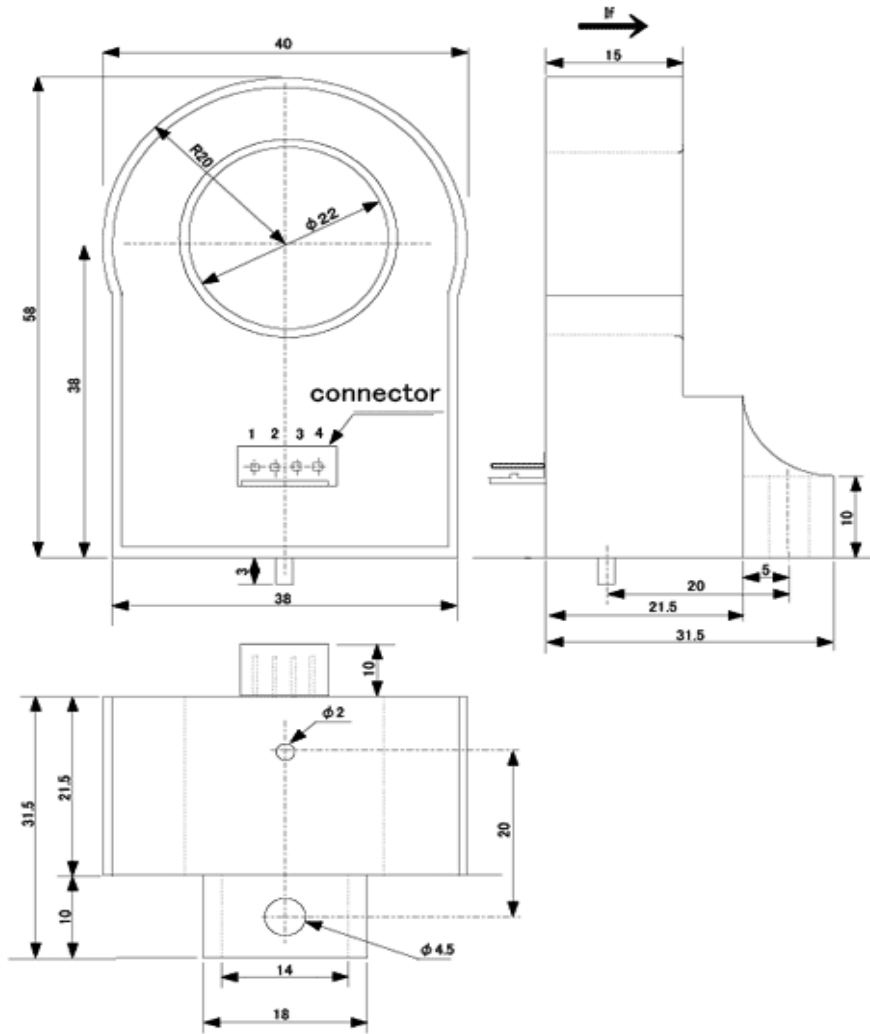

Connector Type[22-11-1041] Maker[Molex]

CSC-21006

Product Name	Mass
CSC-15J	52g

Connection

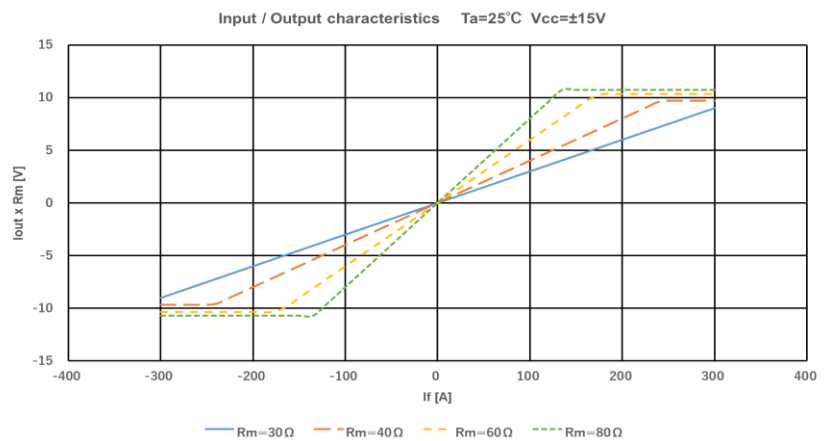
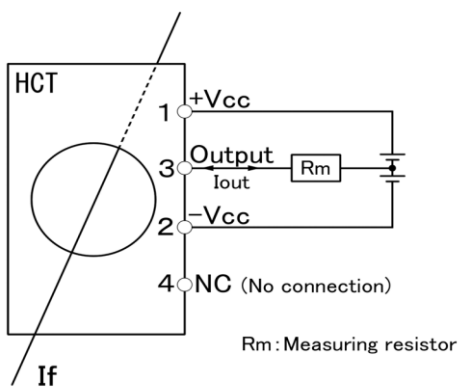

NANA ENGINEERING NANA ENGINEERING CO.,LTD.

1-22-5,Morino,Machida-shi,Tokyo 194-0022

Machida 310 Irago building 4F

E-Mail : nanaeng_sales@nana-e.com

URL : <http://www.nana-e.com>

*Please read the caution of Closed Loop Type before using this product.
http://www.nana-e.com/Precautions_for_use_eng.pdf