

## Features

- High reliability
- Excellent accuracy
- Low thermal drift
- Fast response time
- Excellent linearity

## Closed Loop Type



## Specifications

Ta=25°C

Product name	Code:2653		CEB-600
	Symbol	Unit	
Nominal input current	If(n)	AT	±600
Saturation current	If(s)	AT	±900
Nominal Output current	Iout	mA	Io±120 [at If(n)]
conversion ratio			1 : 5000
Offset current	Io	mA	0±0.40 [at 0A]
Supply Voltage	Vcc	V DC	±15±5%
Consumption Current	Icc	mA	60 + Iout
Response Speed	Trr	μ sec	1 Max. [at di/dt=100A/μ sec]
Thermal Drift of Vh		%/°C	±0.05 Max. [at If(n)]
Thermal Drift of Io		mA/°C	±0.1 Max. [at 0A]
Dielectric Strength		kV	AC 2.5 [with 50 or 60 Hz 1min.]
Insulation Resistance		Ω	500M Min. [at 500V DC]
Operating Temperature	Ta	°C	-20 to +80
Storage Temperature	Ts	°C	-40 to +85
Hysteresis Error		mA	±1.5 Max. [at If --> 0]
Measuring resistance	Rm	Ω	8 ~ 30

# Dimensions

Unit : mm

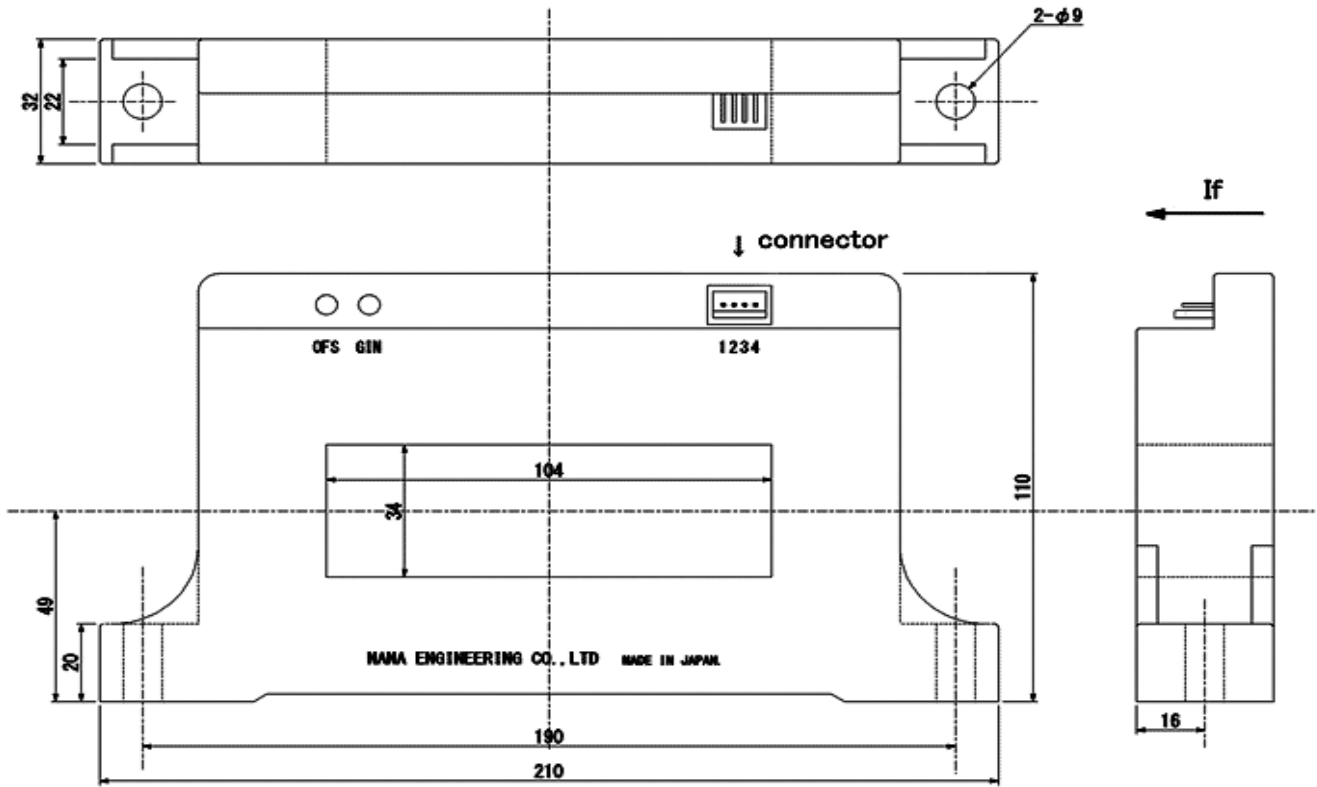

Connector Type[22-11-1041] Maker[Molex]

CEA-21026

Product Name	Mass
CEB-600	680g

## Connection

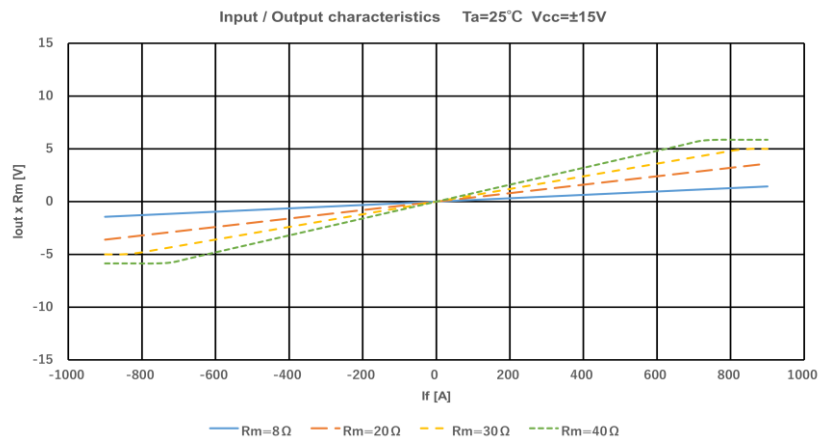
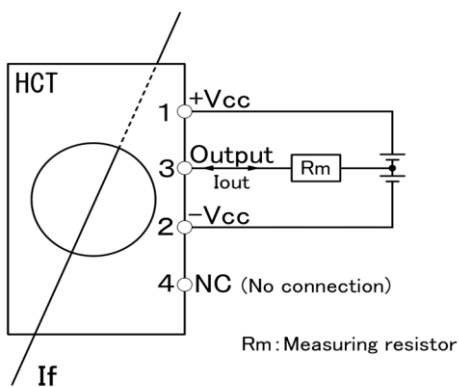

**NANA ENGINEERING CO.,LTD.**

Machida 310 Irago building 4F  
 1-22-5 Morino, Machida-shi, Tokyo 194-0022  
 E-Mail : nanaeng\_sales@nana-e.com  
 URL : <http://www.nana-e.com>

\*Please read the caution of Closed Loop Type before using this product.  
[http://www.nana-e.com/Precautions\\_for\\_use\\_eng.pdf](http://www.nana-e.com/Precautions_for_use_eng.pdf)